



Autocue Limited.
Unit 3 Puma Trade Park,
145 Morden Road, Mitcham,
Surrey CR4 4DG
Tel: +44 (0)20 8665 2992

P.C. 90

Conference Stand

Notice

DISCLAIMER

Autocue Ltd. reserves the right to revise this publication and to make changes to it's content without prior notification.

COPYRIGHT

Copyright © 2001 Autocue Ltd.

All rights reserved.

No part of this publication may be reproduced, stored in a retrieval system or transmitted in any recording or otherwise without prior permission of Autocue Ltd.

Version 1.00 of this manual was written and compiled by
Autocue Ltd. 13 May 2008

PC 90 Conference Stand.

How to use this guide.

Autocue© PC90 Guide provides detailed information on how to set up and operate the Autocue© PC 90 Conference Stand.

Structure of this guide.

Modular in design, and divided into three simple chapters.

Chapter 1 Installation.	How to install the Autocue PC90
Chapter 2 Care.	Describes how to care for the Autocue PC 90 with simple do's and don'ts.
Chapter 3 Technical Information	Describes the specifications of the Autocue PC 90.
Frequently Asked Questions	

Chapter

1

Installation for Autocue PC 90

In this chapter describes the requirements needed to use the Autocue **PC 90** in easy to follow instructions.

System Set-up

The installation of **Autocue's PC 90** is simple and can be covered in 3 easy steps.

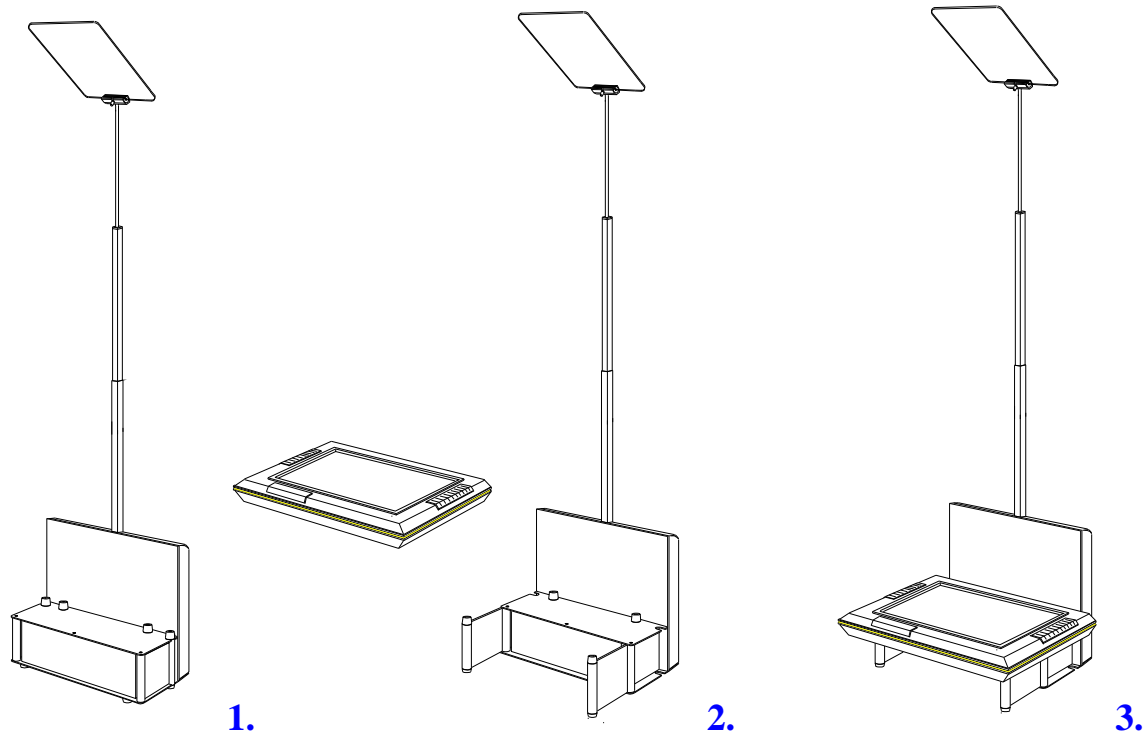

1. Place the PC 90 on a level surface and open the support doors.
2. Stand the 15" FDP Monitor or 17" CRT Monitor onto the PC 90. (15" FDP Monitor shown.)
3. Ensure that the unit is stable by adjusting the angle of the support doors.

Glass Holder

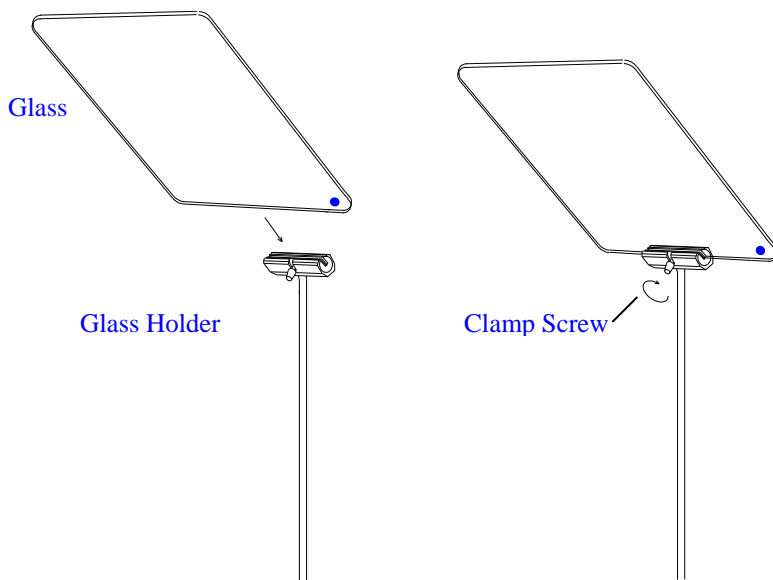

To install the glass into the holder first loosen the clamp screw so that the jaws of the clamp are open. Insert the glass and secure in the clamp by retightening the clamp screw. The angle of the glass is adjustable and must be set at 45 degrees to the face of the monitor. Please insure that the blue dot on the face of the glass is facing the presenter.

Cable Set-up

Attach all relevant cables.

1. Power input.
2. Power output for monitor
3. Data input
4. Local control socket
5. Data output.

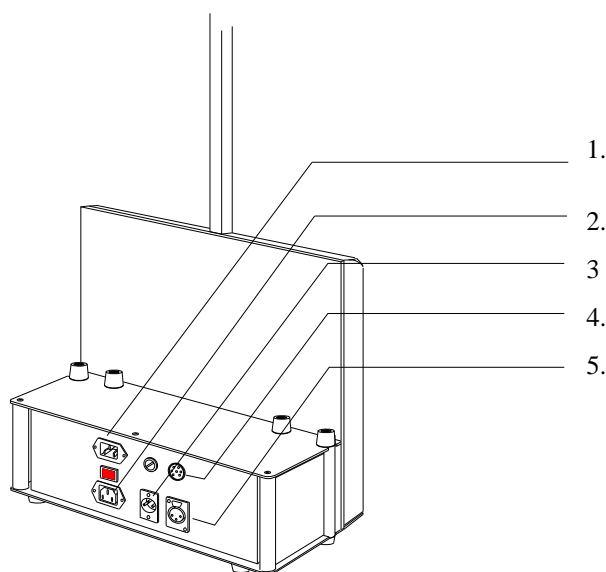

Cable Set-up

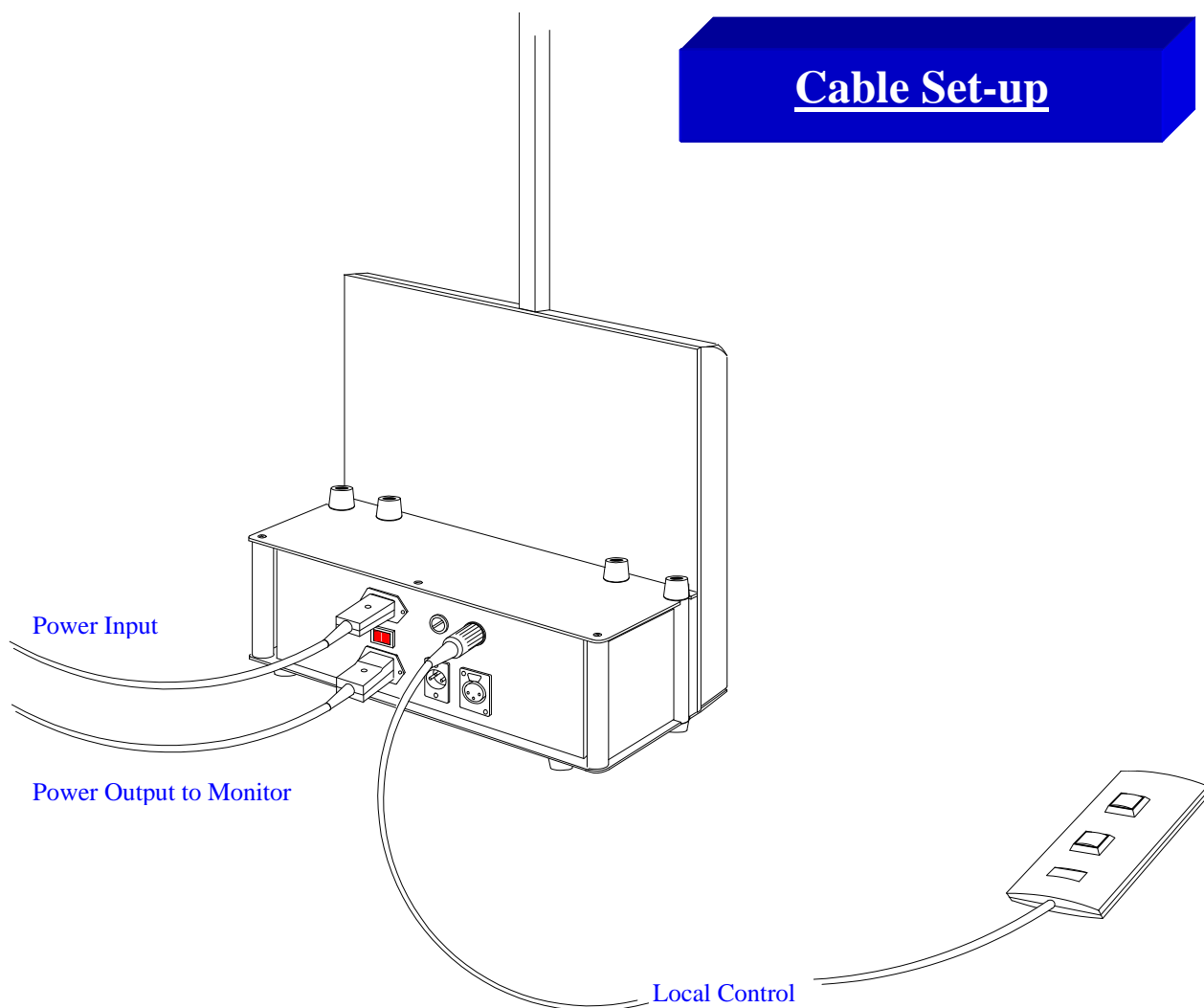

Data Cables

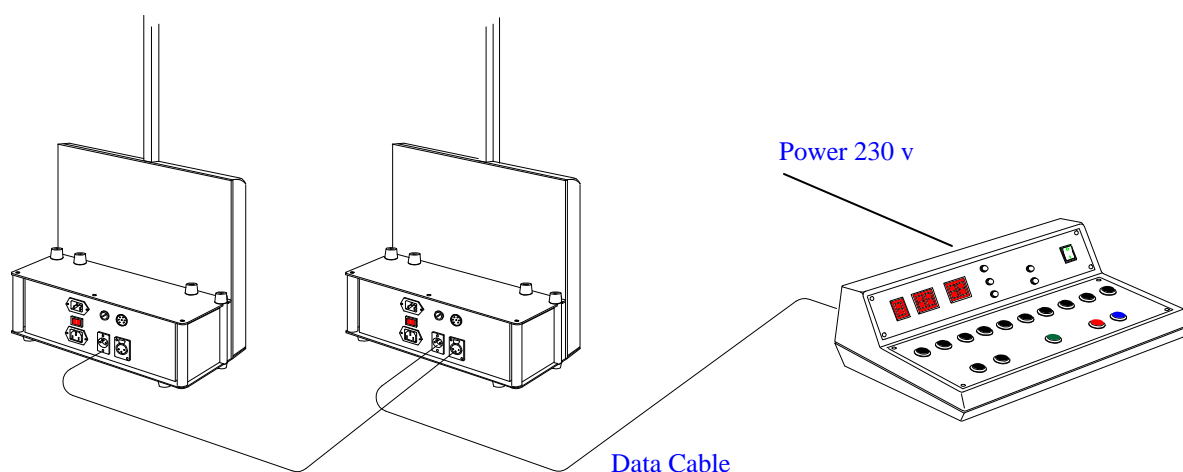

Use the data cables to connect the remote control box to the PC 90 stands. The data cables can be looped through the stands by using the Data input and Data output sockets. Use the power output socket to power the monitor.

Stand Configurations (Individual)

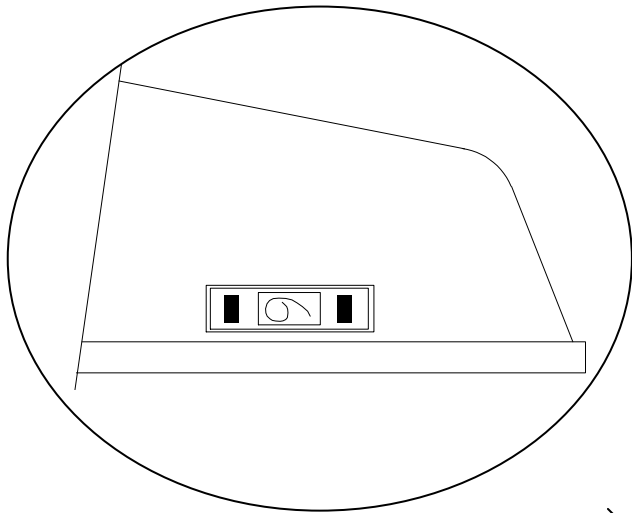

Stand Number Selector

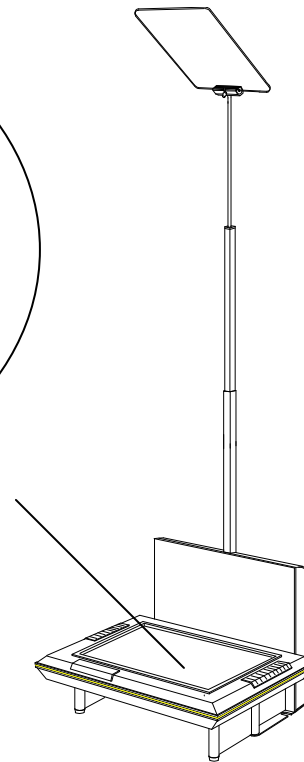

Set to No 1.

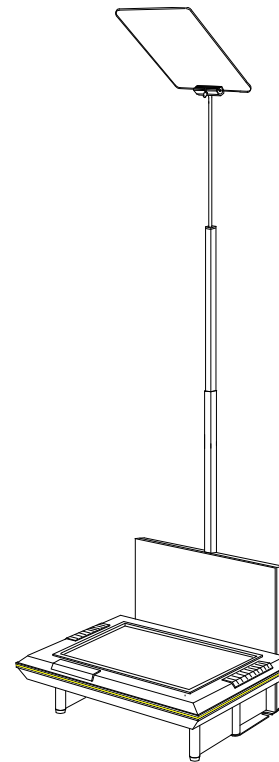

Set to No 2.

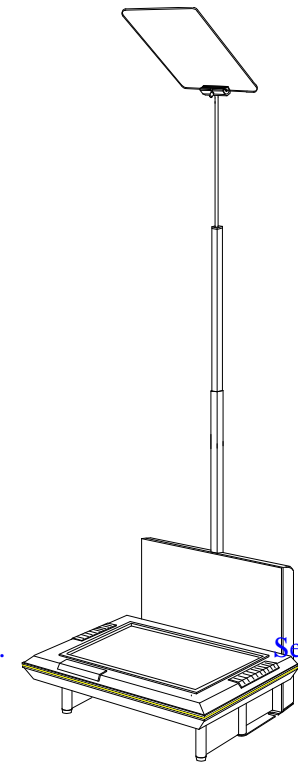

Set to No 3.

In this mode the PC90's work on the principle of one stand at a time being controlled individually. The stands must be numbered 1 to 9 use the Stand number selector switch that is located on the 'Shoulder of each stand to change the number.

When the stand number 1 is selected and a new height is entered stand 1 will move to the new height.

When the stand number 2 is selected and a new height is entered stand 2 will move to the new height.

A maximum of 8 stands can be controlled in this way.

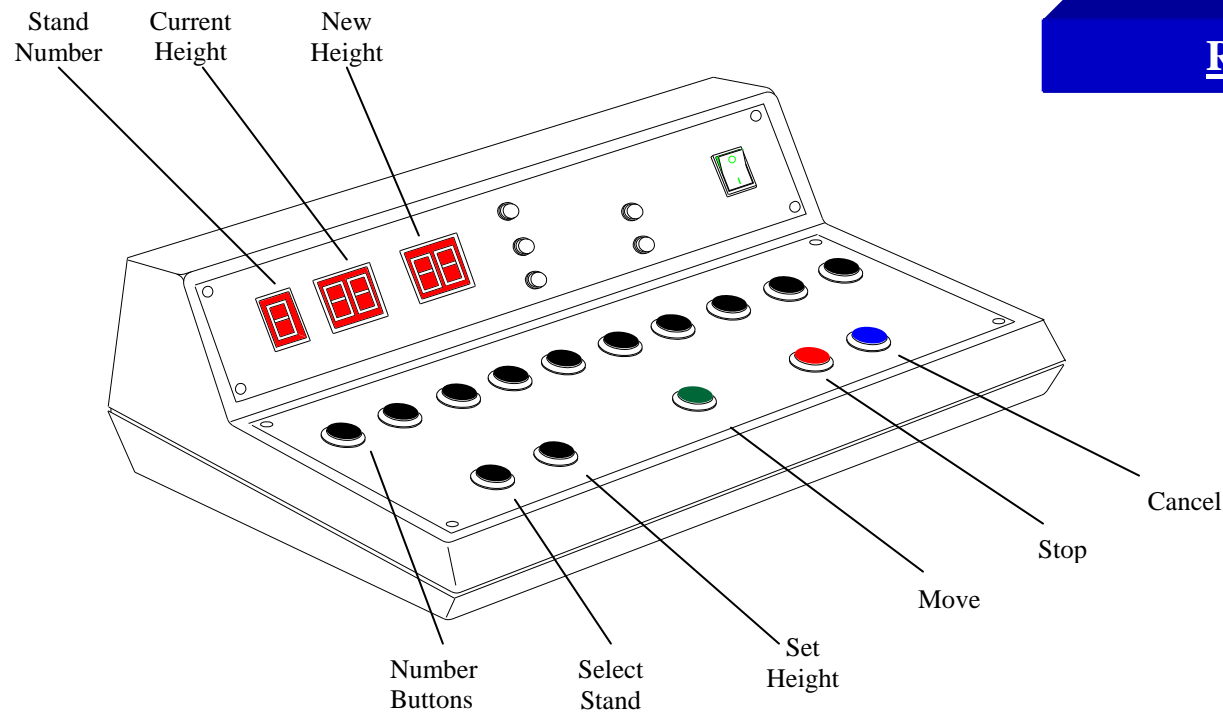

Remote Control Operation

The remote control panel will control PC 90 stands individually or in groups. It will display the current height of the stands, the stand number selected, and the new height you wish the stand to move to.

When all the stands are correctly connected and powered and switched on, the Remote Control Box will take a few seconds to automatically detect any stands that are connected to the system.

Operation

Press **Select Stand** and input the required stand number (1,2,3) using the number keys, the new stand number is now displayed in the **Stand Number** window. The “**Current Height**” of the selected stand will be displayed in the **Current Height** window on the Remote Control Box. At the stands, set the required height of each individual speaker by using the **Local Control**, making a note of the Current Height displayed on the Remote Control Box. To move the stands to the pre-determined heights, press **Select Stand** and enter the number (1,2,3), then press **Set height** and enter the required height number 01 to 84. The new height will be displayed in the **New Height** window. Now press **Move**, the stand or group of stands will now move to the new height entered. Pressing the **Stop** button will stop the command and the **Cancel** button enables you to change the **Stand Number** and **Stand Height**.

Stand Configurations (Grouped Stands)

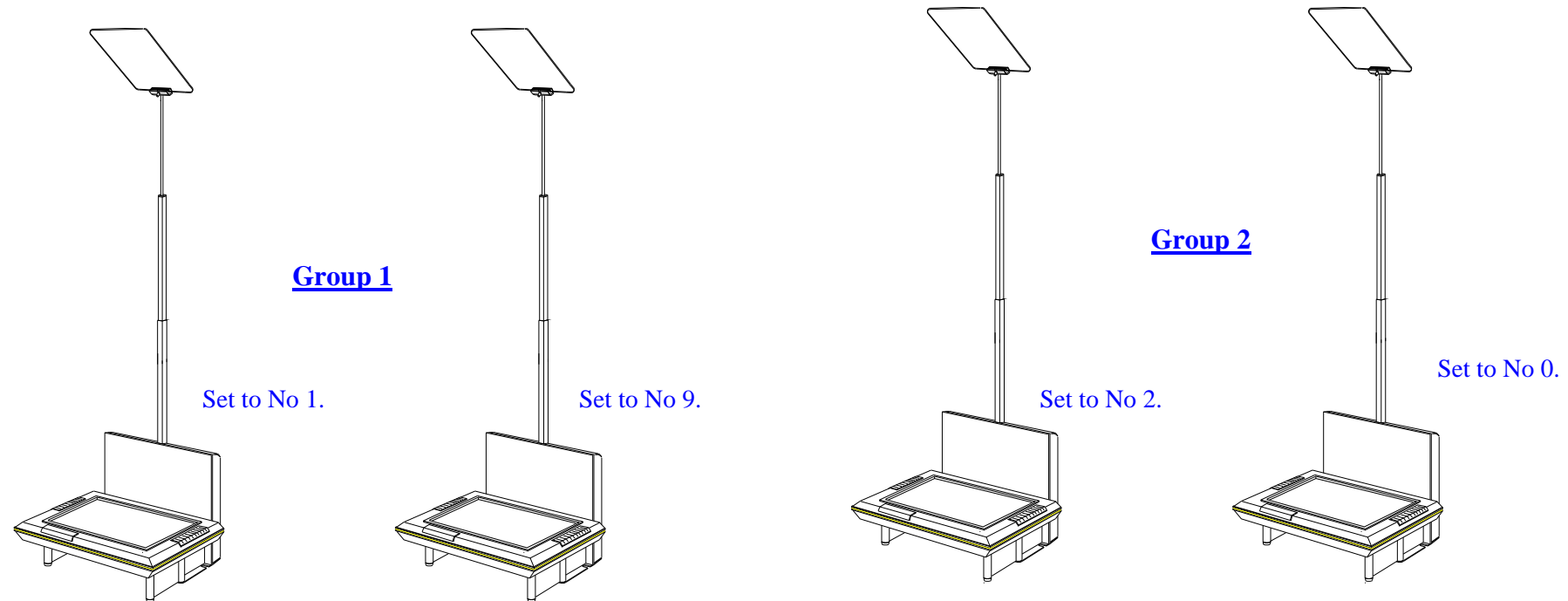

In this mode the PC90 works on the principle of one Master and one or more slave stands in each group. The master stand in each group must be numbered either 1 or 2, using the Stand number selector switch that is located on the 'Shoulder of each stand.

The Slave Stand or Stands of number 1 must be numbered 9. The slave Stand or Stands of number 2 must be numbered 0.

When the stand number 1 is selected and a new height is entered all stands in-group 1 will move to the new height.

When the stand number 2 is selected and a new height is entered all stands in-group 2 will move to the new height.

Chapter

2

Care Instructions

This chapter is a brief introduction to the best ways to keep the **Autocue PC 90** working, with a simple list of **do's** and **don'ts** so as the equipment is at its optimum efficiency.

3. Care for the Autocue PC 90

Don'ts:

- ❑ Drop or place in a position where it may be knocked or dislodged.
- ❑ Use an abrasive cleaner on the glass surfaces.
- ❑ It is very important that the stands movement is not forced up or down by hand.

Do's:

- ❑ To clean glass use tepid water mixed with a few drops of soft detergent.

Chapter

3

Technical Information PC 90

Control Panel

Power Switch	On/Off
AC Power Input Socket	IEC Connector, 230 volts, 50 Hz
AC Power Output Socket	IEC Connector, 230 volts, 50-Hz
Data Input	3 Pin XLR
Data Output	3 Pin XLR
AC Fuse	5 amp, 20 mm
Remote Control Socket	6 Pin Din

Dimensions

Sand Height Maximum	2000 mm
Stand Height Minimum	1000 mm
Overall Footprint (With 15" FDP Monitor)	500 mm x 500 mm

Frequently Asked Questions

Below is a list of the more frequent questions received by our Prompter support team. To save you and us time, we have completed this section of the manual to answer those questions most frequently asked.

- **How do I clean the glass?**

As recommended by the manufacturers, use tepid water with a small amount of detergent to clean the glass, then leave to dry naturally.

You can also clean the glass periodically with a clean and dry non-abrasive duster.

Warning: Do not clean the glass with abrasive cleaners or dusters, these will scratch the glass coating and it will have to be replaced!

- **On which side should the paper dot face?**

The dot on the glass should face the presenter. If the dot is facing the wrong direction it will produce a double image effect.

- **If the stand stops responding**

Reset by switching off and switching on again.

Notes